

## Telemetric Voltage Monitors – TVM1, TVM3 Wireless Monitors with Outage Detection and Voltage Monitoring

The TVM monitors line voltage and provides real-time notifications of steady state values, outages and under or over voltage conditions. Different models are available for monitoring single phase and three phase grounded systems. Data is available to utility SCADA systems and Outage Management Systems through Telemetric's SCADA Xchange™, or from the Telemetric PowerVista™ hosted applications.

The TVM includes an integrated two-way radio that communicates over the AT&T/Cingular GSM cellular network, with excellent coverage in North America. No license or local cellular account is required. The device can be placed anywhere there is AT&T/Cingular or roaming partner cellular phone coverage.

All monitors transmit data using General Packet Radio Service (GPRS) technology on AT&T GSM networks. Models available:

- **TVM1-120-GSM**, 120VAC, single phase
- **TVM3-120-GSM**, 208Y/120VAC three phase
- **TVM3-277-GSM**, 480Y/277 VAC three phase

The TVM3-120 model can also be used for 240/120V, 3 wire, single-phase service.

### Features and Benefits

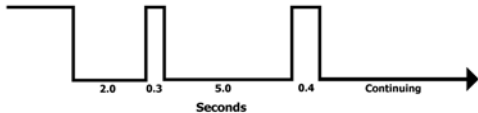
- Reports power outages, including:
    - Time and location of the event
    - Number of state changes (for example, off-on-off-on-off = 5)
    - Final state (AC power ON or OFF)
    - Timing details of the first seven state changes
- 
- Reports over (OV) and under (UV) voltage events, including the event duration, using three remotely programmable under-voltage set points and two over-voltage set points. This includes type II and III power quality events based on the ITIC (CBEMA) voltage curve (50 ms or greater)

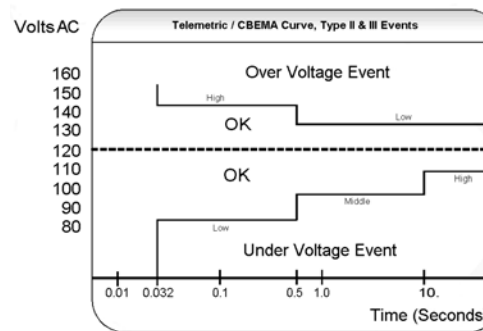

- The present, minimum and maximum measured AC voltage can be reported at preset frequencies or anytime upon request. True RMS measurement of the steady state voltage provides accurate readings. The present, min and max readings can be averaged over 3 seconds or 96-seconds
- Voltage unbalance calculations and alarms using NEMA definition (three phase models only)
- Units are shipped with Steady State Defaults. A single command from the hosted PowerVista application can change to Power Quality Defaults
- All programmable operating parameters are remotely adjustable from the PowerVista applications
- Communications are initiated for three reasons:
  1. An outage or over/under voltage occurs, triggering a report
  2. Time-scheduled reports can be scheduled from once every hour to once every 240 hours (10 days)
  3. User requests a report through the Intelligent Web Server or SCADA system
- Provides critical outage and power reliability data that can be used to create reports required by Public Utility Commissions, Corporation Commissions and other regulatory agencies
- Data can be exported via a CSV file using the PowerVista applications
- Optimizes usage of field crews and dispatch personnel by providing the exact location of outages
- Devices are light weight and simple to install



# Specifications

## Voltage Measurement

- True RMS measurement for high accuracy steady state readings ( $\pm 0.7\%$  VAC for  $-20^{\circ}$  to  $50^{\circ}\text{C}$ , max  $\pm 1\%$ )
- Instantaneous voltage readings for OV & UV events ( $\pm 2\%$  VAC for voltages exceeding 60 volts)
- Reports the duration and minimum or maximum voltage of sags and swells 3 cycles or longer

## PowerVista™ Hosted Applications

- Data is secure and password protected
- Server authentication using 128-bit encryption key validated by VeriSign Trust Certificate
- E-mail, text messages and pager event notifications are included at no extra cost (see PowerVista datasheet)

## SCADA Interface

- All Telemetric devices can be monitored and controlled through an existing SCADA or OMS system via DNP3 (see SCADA-Xchange datasheet).

## 96-Second Averaging Option

- The present, minimum and maximum AC voltages can be measured as RMS values or can be averaged over a 96-second period (using an average of 16 readings with a new reading every 6 seconds). Averaging will filter out short voltage transients.

## Cellular Data Network

- Transmit power: 0.1 to 1.2W
- Dual-band, supporting GSM/GPRS 850/1900MHz
- 50 Ohm SMA antenna connector
- Omni, 1/2 Wave, 2.5dB antenna included

## Operating Power

- Standard: 120 or 277VAC ( $-17\%/+13\%$ ), 60 Hz
- Battery backup (Nonspillable, sealed, lead-acid; 5 year expected life) with automatic charger

## Environmental Data

- Operating Temperature:  $-40^{\circ}$  to  $+70^{\circ}\text{C}$
- Electrical Transient Immunity per ANSI/IEEE C37.90.1-2002

## Enclosure

- NEMA 3R enclosure rating
  - Integrated mounting flanges
  - Hinged lockable door
  - Gray non-metallic construction
  - Meter base options available
- Three conduit compatible cable entry holes
- Dimensions: 8" x 7" x 3"
  - Weight: 4 pounds

PROGRAMMABLE PARAMETERS <sup>2</sup>			
Feature	Steady State Defaults	Optional Power Quality Defaults <sup>1</sup>	Possible Values
Power Outage Trigger Time (outages lasting longer than this will be reported)	5 minutes	32 mSec	32, 50, 64 mSec or 0.1, 0.5, 1, 2, 5, 10, 30 seconds or 1, 2, 3, 4, 5, 8 or 10 minutes
High Under Voltage Set Point	115 VAC	108 VAC	100 – 125 VAC
High Under Voltage Trigger Time	5 minutes	10 seconds	0.2, 0.5, 1, 2, 5, 10, 30 seconds or 1, 2, 5, 10, 30, 60 minutes
Middle Under Voltage Set Point	110 VAC	96 VAC	90 – 120 VAC
Middle Under Voltage Trigger Time	1 minute	0.5 seconds	0.2, 0.5, 1, 2, 5, 10, 30, 60 seconds
Low Under Voltage Set Point	80 VAC	84 VAC	80 – 100 VAC
Low Under Voltage Trigger Time	30 seconds	50 mSec	50, 64 mSec or 0.1, 0.2, 0.5, 1, 2, 5, 10, 30, 60 seconds
High Over Voltage Set Point	130 VAC	144 VAC	120 – 150 VAC
High Over Voltage Trigger Time	30 seconds	50 mSec	50, 64 mSec or 0.1, 0.2, 0.5, 1, 2, 5, 10, 30, 60 seconds
Low Over Voltage Set Point	126 VAC	132 VAC	115 – 140 VAC
Low Over Voltage Trigger Time	5 minutes	0.5 seconds	0.2, 0.5, 1, 2, 5, 10, 30 seconds or 1, 2, 5, 10, 30, 60 minutes
Daily Call Limit	12 per day	12 per day	4, 8, 12, 16, 20 calls per day or unlimited (for test/demo)
Time Scheduled Report Frequency	Off	Off	1 report every 1, 2, 4, 8 hours or 1, 2, 7, 10 days or Off
96-Second Averaging	Off	Off	On / Off
Duration Reporting	On	On	On / Off
Voltage Unbalance	Off	Off	On/Off; set point 0.5 to 10%; trigger time 180 to 3600seconds

<sup>1</sup> Units are shipped with Steady State Defaults. A single command from the PowerVista can change to Power Quality Defaults.

<sup>2</sup> All voltages on a 120V base